

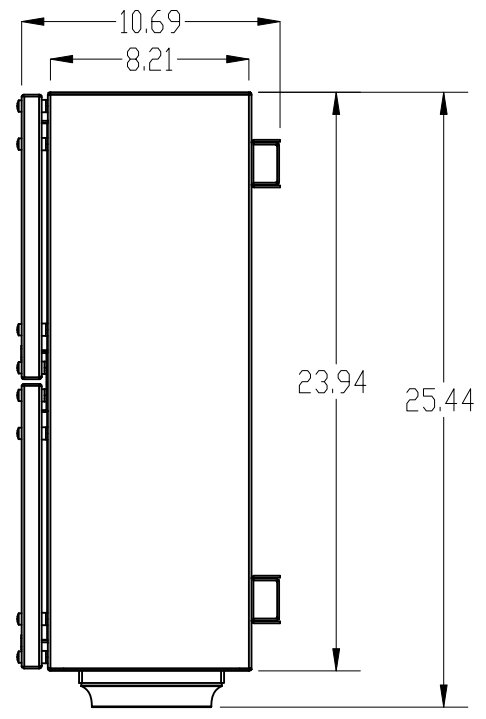

This drawing is the property of MELTRIC Corporation, Franklin (Milwaukee), Wisconsin, USA. Any unauthorized copying of this drawing by any means, or disclosure of its contents to any person not authorized by MELTRIC Corporation or its agents to receive it, is strictly prohibited.

G F E D C B A

DEVICE	PART NUMBER	NPT SIZE
PFQ	47-4A023-N020	2" NPT
PFQ	47-4A023-N025	2.5" NPT
PFQ	47-4A023-N030	3" NPT
PFQ	47-4A023-N040	4" NPT

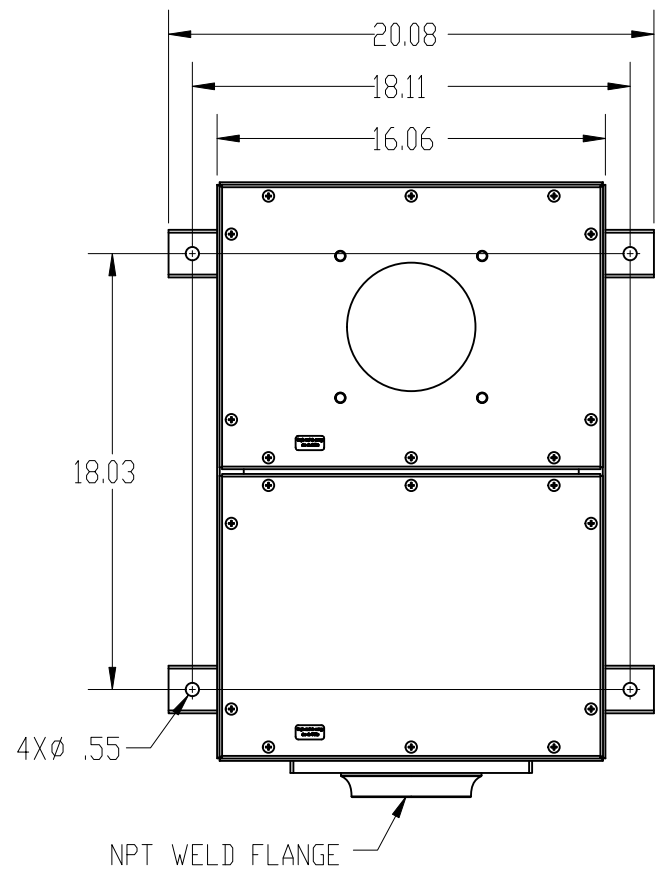
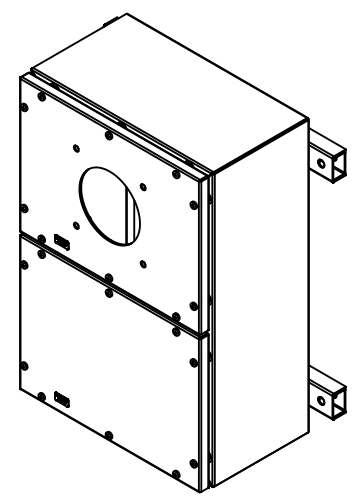

TOLERANCES UNLESS OTHERWISE SPECIFIED MACHINED SURFACES $\sqrt{125}$ MAX GROUND SURFACES $\sqrt{32}$ MAX ANGLE TOLERANCE $\pm 1^\circ$ REMOVE BURRS & SHARP EDGES TO .015 MAX.  DIMENSIONS SHOWN IN OVALS ARE INSPECTION DIMENSIONS.		ENGLISH 0.X ± 0.05 0.XX ± 0.01 0.XXX ± 0.005		 A COMPANY OF MARÉCHAL ÉLECTRIC	
DRAWN: _____ DATE: _____	APPROVED: _____ DATE: _____	DRAWING TITLE: STAINLESS STEEL JUNCTION BOX, 24"x16"x8"		MATERIAL: STAINLESS STEEL	
SHEET: 1 OF 1		PART NUMBER 47-4A023-N0xx		REVISION	