

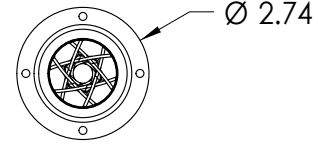

This drawing is the property of MELTRIC Corporation, Franklin (Milwaukee), Wisconsin, USA. Any unauthorized copying of this drawing by any means, or disclosure of its contents to any person not authorized by MELTRIC Corporation or its agents to receive it, is strictly prohibited.

G F E D C B A

PART NUMBER	CABLE RANGE
45-4A753-A	.750-.875"
45-4A753-B	.875-1.000"
45-4A753-C	1.000-1.125"
45-4A753-D	1.125-1.250"
45-4A753-E	1.250-1.375"

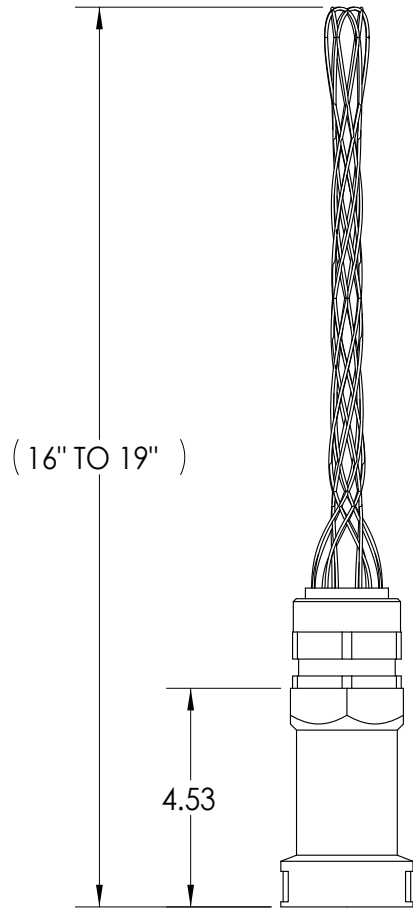

TOLERANCES UNLESS OTHERWISE SPECIFIED		 A COMPANY OF MARECHAL ELECTRIC	
MACHINED SURFACES $\sqrt[125]{\text{MAX}}$ GROUND SURFACES $\sqrt[32]{\text{MAX}}$ ANGLE TOLERANCE $\pm 1^\circ$ REMOVE BURRS & SHARP EDGES TO .015 MAX.	ENGLISH 0.X ± 0.05 0.XX ± 0.01 0.XXX ± 0.005		
DIMENSIONS SHOWN IN OVALS ARE INSPECTION DIMENSIONS.		SCALE: NTS	MATERIAL: POLY HANDLE, SS MESH
		SHEET: 1 OF 1	PART NUMBER: 45-4A753-x
		REVISION: _____	